

PLANT CELLS AND ANIMAL CELLS

General Science, Biology, Anatomy, Physiology

Grades 6–12

OBJECTIVES

CONTENT

Students will learn the role of cells as building blocks of all living structures. They will differentiate between plant and animal cells with regard to their structure, function, and components.

THINKING SKILL/PROCESS

Students will learn to compare and contrast skillfully by finding significant similarities and differences, determining patterns in the similarities and differences, and by reaching a conclusion based on the comparison and contrast.

METHODS AND MATERIALS

CONTENT

Students use diagrams of a typical plant and animal cell and relevant textbook material to learn about their structure and function.

THINKING SKILL/PROCESS

This lesson features structured questioning, a compare and contrast graphic organizer, brain storming and metacognitive reflection to develop a plan for comparing and contrasting skillfully.

LESSON

INTRODUCTION TO CONTENT AND THINKING SKILL/PROCESS

- Ever notice how two things can do the same job but look different.? For example, let's consider bricks and cinderblocks. Both are basic building materials used in the construction of buildings. **Can you think of similar ways that these materials are used?** Ask for responses from the class. TYPICAL STUDENT RESPONSES INCLUDE: *When piled on top of each other they make up foundations which support an entire building. They are used to make walls that support floors and the roof of a building. Both are used to make fireplaces inside buildings.* **Can you think of other uses of these materials that are similar?** TYPICAL STUDENT RESPONSES INCLUDE: *They can also be used for building roads and for creating pathways. Both can be used to make retaining walls by landscapers. Both are found in the construction of dams.* **Things used to make buildings are called "materials of construction."** **Can you name other materials of construction? Think about building a house.** Have students brainstorm a list of common building materials. STUDENT RESPONSES INCLUDE: *lumber, nails, siding, cement, mortar, plywood, roof shingles, insulation, pipes, girders, rebar, sheetrock, screws, molding, doors, hinges, etc.*
- Although similar building materials are often used to accomplish the same building purpose, there are times when the differences between them make one a much better choice than the other. Architects earn their living by knowing all about building materials. They have learned to tell the differences between similar materials of construction and then choose which is best for a given job. For example, brick walls on a house look nice, but cinderblocks, if not plastered over with stucco or some other covering, would often look unattractive. Usually an architect will choose brick instead of cinderblocks for the exterior walls of a fine

home because the characteristic of attractiveness is very important. Although cinderblocks could do the same job, they are rarely used for house exterior walls. Where do you usually find cinderblocks used as a material of construction for walls? Have students brainstorm a list in the class and report the items on their list. Ask for one item only from each student who responds. TYPICAL RESPONSES INCLUDE: *supermarkets, warehouses, lumber yards, gas stations, factories, underground foundations, basement walls, the walls of a school building.* Discuss with students the fact that in cases like these function is more important than good looks.

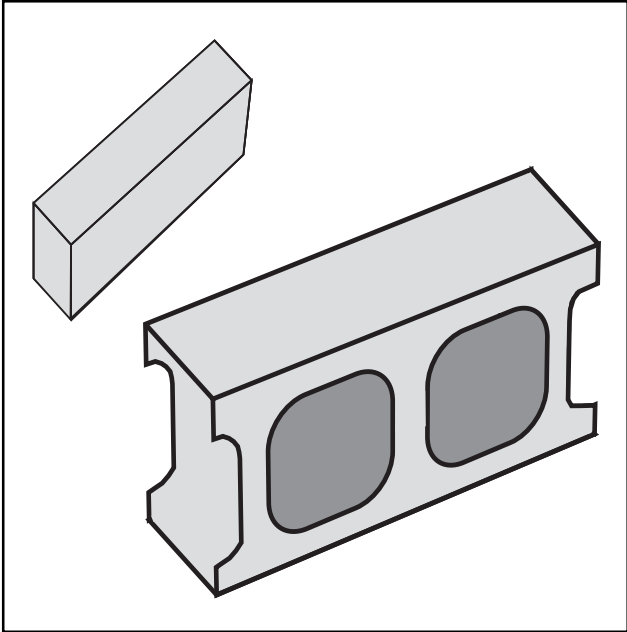

- Meet in your groups and make a list of differences between bricks and cinderblocks that might determine different uses, just as the look of these two types of building materials is what determines their use in the situations we just discussed.** Pass out a diagram of a typical brick and cinderblock. Also, if available, bring a brick and a cinderblock to class so that students can examine them. TYPICAL RESPONSES INCLUDE: *Bricks are solid, cinderblocks are hollow. Bricks are smooth, cinderblocks are rough. Bricks are small; cinderblocks are much larger. Bricks come in colors like red, tan, and orange; cinderblocks are usually gray. Bricks are solid; cinderblocks have passageways through which pipes can travel. Bricks cannot be reinforced; cinderblocks are sometimes filled with concrete and iron rods.*
- Can you think of other building materials which can do the same job but look different?** ANSWERS VARY BUT SOMETIMES INCLUDE: *Lumber and steel, vinyl siding and stucco, plastic (PVC) and lead pipes, tile and wood flooring, paneling and paint, screws and nails, flathead and roundhead screws, brads and nails.*
- What other characteristics do you think building materials might have that would determine how and when they are used?** TYPICAL STUDENT RESPONSES INCLUDE: *how easily they bend (flexibility), how brittle they are, if they are waterproof, whether they are coarse or smooth, how much they weigh, their size, their shape, how long they last, their availability, their cost.*
- Another name for the process of looking at similarities and differences in order to reveal important characteristics of things is called comparing and contrasting. In the example of bricks and cinderblocks, we compared the similarities they both shared and then we contrasted their differences. Once we know these distinctions we are in a good position to draw an intelligent conclusion about which material would work best for a particular job. This is a thinking map of the questions that can guide us in engaging in this kind of comparing and contrasting. Notice how these questions include, but go beyond, asking only about similarities and differences. This is a typical way of comparing and contrasting. We're going to use this map to guide us through an activity in science in which we will explore the basic building blocks of living material.**

OPEN COMPARE AND CONTRAST

1. How are they similar?
2. How are they different?
3. What similarities and differences seem significant?
4. What categories or patterns do you see in the significant similarities and differences?
5. What interpretation or conclusion is suggested by the significant similarities and differences?

THINKING ACTIVELY

- Just as a house or a factory are made up of lots of basic building units like bricks and cinderblocks, the structures of nature—trees and fish and people—are also made up of basic materials of construction. The primary building blocks of living things are called cells. Cells, in fact, are the smallest units of construction which are able to carry on all the activities of living things. In this lesson, we are going to compare and contrast animal and plant cells to see what we can learn about these building blocks of living things.
- First, let’s read some material about the structure and function of plant and animal cells. Distribute copies of the Animal Cell/Plant Cell Source Material to each student. As you read about plant and animal cells, be sure to look closely at the diagrams of each so that you can identify their structures. Allow students 6 or 7 minutes to become familiar with the material.
- Now that each of you has had time to become familiar with the layout of plant and animal cells, organize yourselves into groups of four or five students each and examine the reading material and the diagrams more closely. Reread the material on animal and plant cells and look for similarities and differences between them. Use the compare and contrast diagram to record how they are alike and different. Distribute a copy of the Open Compare and Contrast graphic organizer to each group. When you discover similarities, list them in the box headed “How Alike?” The differences between the animal cell and the plant cell are less obvious. Be sure to read the material very carefully and examine the cell diagrams closely. When you find a difference, put it in the boxes under “How Different?” and think about what kind of difference it is, recording this in the box under “With Regard To.” For example, you will notice immediately that plant cells are green and animal cells are colorless. That’s a difference with regard to what? The cell’s color. Record the word “color” in the box under “With Regard To.” If another example is needed, refer back to the earlier discussion of the differences between bricks and cinderblocks. Recall that during your discussion of bricks and cinderblocks they noted that bricks are small and cinderblocks are large. Ask what characteristic is being referred to. They should readily answer “size.” Allow 9 or 10 minutes for group work on the compare and contrast graphic organizer.

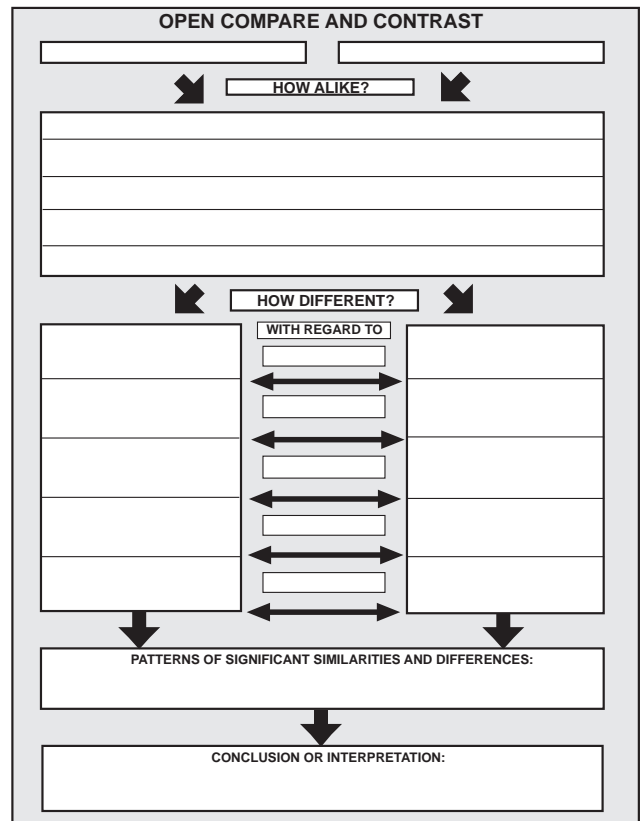

- **How are animal and plant cells alike?** After students complete significant work on their group graphic organizers, have one member of each team report back to the class by describing one similarity. Record responses on the chalkboard or a transparency made from the blackline master in this chapter. As students report on the similarities their group found, ask them questions of clarification that help them to elaborate the similarity and /or note its consequences or what it reveals about these cells. Encourage students to make use of information from the source material they have just read and anything they already know about these cells. TYPICAL

STUDENT RESPONSES: *They are both basic building blocks of living material. They both have a nucleus. They both have a cell membrane. They both have cytoplasm. They both are usually very small and require a microscope to see. They both reproduce by cell division. They both contain chromosomes. They both come in many sizes and colors. They both carry genetic material called DNA. They both can grow. They both can repair themselves. Plants and animals have many cells. Many different kinds of cells are found in plants and animals. The proper operation of the cells in both plants and animals keeps the plants and animals alive.*

- **How are animal and plant cells different?** As the reporter from each group contributes a difference, record the difference and ask him or her what kind of difference this is. Note the type of difference in the boxes beneath the “With Regard To” heading on the transparency or diagram you have written on the chalkboard. Ask the student who mentions the difference what it reveals about these cells. STUDENT RESPONSES INCLUDE: *Plant cells have a cell wall; animal cells have membranes only; Plant cells have one huge central vacuole; animal cells have several small vacuoles, if any. Plant cells have chloroplasts and mitochondria for energy production; animal cells have only mitochondria for energy production. Plant cells undergo photosynthesis; animal cells undergo cellular respiration. Plant cells are rigid; animal cells are flexible. Plant cells are usually green; animal cells are usually colorless. Plant cells have chlorophyll; animal cells don't. Plant cells need light to function properly; animal cells can function in darkness. Many kinds of animal cells have flagella for motion; only some plant sperm cells have flagella. Plant cells take in carbon dioxide from the atmosphere and give off oxygen; animal cells take in oxygen from the atmosphere and give off carbon dioxide.*
- **Now that you have stated how animal and plant cells are similar and different, we will use this information to give us insight into how and why these cells could be so much the same, yet in some ways very different. To do this, we will follow the thinking map for comparing and contrasting by asking the remaining three questions about the similarities and differences. Meet in your groups and first determine which of the similarities and differences you've come up with are significant. If a similarity or difference seems not very significant, draw a line through it. Then, see if you can discover some patterns of similarities and differences or major themes in what remains in the “How Alike” and “How Different” boxes. Write these, using only a word or short phrase, in the “Patterns” box on your diagram. It may be useful here to have students remember the earlier example of the brick and the cinderblock. Ask them to brainstorm an answer to this question: “Can you come up with a pattern of similarities and differences that might explain why bricks are used sometimes and cinderblocks preferred at other times?”** Students easily recognize that there is a pattern relating to appearance, cost, strength, and versatility in both bricks and cinder blocks, with bricks exemplifying a higher degree of these qualities. After giving students a few minutes for reflection, discussion, and recording their responses on the graphic organizer, ask for reports from a few groups using the same technique as used in getting reports about the similarities and differences they found. STUDENT RESPONSES INCLUDE: *Structure and components relate to what the cells do. Many cells make up both plants and animals. Both kinds of cells are basic building blocks. Internal mechanisms lead to cell reproduction and the growth of the living thing the cell is part of (variety of functions, variety of components). What happens inside these cells remains constant while changes are produced (energy users and producers).*
- **In your groups, think about and discuss these patterns of significant similarities and differences. Then express one or more of these patterns in some important insight or conclusion you come to about these two types of cells. Formulate your conclusion in one sentence only and write it in the “Conclusion or Interpretation” box on your team's graphic organizer.** If students aren't sure what you mean when you ask them to draw a conclusion, explain that a conclusion is not a summary of the similarities and differences but rather a statement that goes beyond what is in the list of similarities and differences yet is supported by

them. Go back to the example of bricks and cinder blocks and give an example like “Cinder blocks are important to consider for buildings in which strength is needed and cost is a factor; bricks are important when these building materials show and looks matter.” Explain to students how this goes beyond the similarities and differences stated earlier, yet is supported by them. You may also wish to tell students that you want them to come up with more substantive conclusions than just that both kinds of cells have some similarities and some differences. STUDENT RESPONSES INCLUDE: *The structure of typical plant cells reflects the basic features of plants, for example rigid walls for stem and trunk strength and chlorophyll for photosynthesis; animal cells similarly reflect basic features of animal life, for example flexible membranes and no rigid walls for mobility. Animal and plant cells both use raw materials to make the products and energy essential to sustain the activity and life of the things that they are part of. Cells are like factories using complicated activities for producing the ingredients that keep living things alive; but typical plant cells do this through mechanisms that involve photosynthesis triggered by light, and typical animal cells do this by using mechanisms that involve the breakdown of foods like glucose.*

- **Each member of your group should now pair up with a member of some other group for an activity called “Think-Pair-Share.” In this activity, I would like one member of the pair to read his or her conclusion to the other, and the other member of the pair to help that person clarify and extend their thinking about their conclusion. The way the second member will do this is only by asking questions, not by making statements. There are three types of questions that can be asked:**

Questions of clarification: If you don’t understand what a word or a statement means, you may ask questions to help you understand what is being said. For example, you may ask “What do you mean when you say _____?”

Questions that extend the idea: If you think your partner is saying something interesting, but it is too brief, you can ask for more details about your partner’s idea. You might say something like “What more can you tell me about _____?”

Questions to challenge what is said: If you think the speaker is misled or confused, you may ask questions you think may prompt your partner to rethink or restate some part of his or her statement like “Why do you think _____?” Maybe the speaker will explain why and you won’t think the statement is confused anymore, or maybe the speaker will reconsider aspects of the statement.

After two minutes of reflection, signal students to change roles. After both partners have served as speaker and listener, allow students an opportunity to rewrite their statement in any way they see fit. Then ask if anyone would like to read the sentence to the whole class. Accept two or three students reading their sentences. Ask these students to read their sentences twice and ask the other students to listen to each statement, once for content and once for the kind of statement that is being read (comparison, contrast, comparison and contrast, generalization, etc.). Then, ask the class to suggest what type of information from the similarities and differences noted could be offered to support the statement if the statement was the main idea for an essay assignment. Create a composite bulletin board of students’ conclusions about the two types of cells.

THINKING ABOUT THINKING

- **Let’s stop thinking about plant cells and animal cells and focus our attention on what we did to think about these two types of cells. What kind of thinking did we do?** Students rapidly identify the type of thinking as comparing and contrasting. **What did we do to compare and contrast the two types of cells? What, for example, did you think about first? Next?** Prompt

students to recall the steps in the process. Record their strategy on the board or use a transparency of the thinking map that was identified in the introduction, uncovering each step as students identify it. Review the discussion for each step of the thinking map of open compare and contrast.

- **How was the compare-and-contrast process different from just identifying similarities and differences? Is this way of comparing and contrasting more or less helpful in thinking about things? How?** Student answers usually focus on how this way to compare and contrast helps them to think about what they are comparing and contrasting more carefully than they would if they just listed similarities and differences, and to understand what they are comparing and contrasting much better. They comment that having to draw a conclusion, especially, gives them a chance that they rarely have to formulate ideas of their own about what they are comparing and contrasting.
- **How did the way that you compared and contrasted the two types of cells differ from the way you usually study important concepts in science?** Students say that comparing and contrasting helps them look for important information as they read different passages, instead of trying to learn everything in case it will be on a test.
- **Was using the graphic organizer helpful to you? How?** Students comment that using the diagram assists them in recording details that they notice and might otherwise forget. They also say that the graphic organizer helps to lead them to draw a conclusion from the similarities and differences they have listed.
- **In the Think-Pair-Share activity, was writing out your statement beforehand important?** Students recognize that, for clarity and ownership, having their thoughts written down before discussion frees them to examine the meaning and implications of their conclusions.

APPLYING THINKING

Immediate Transfer

- Compare and contrast two parallel processes in plant and animal cells—for example, meiosis and mitosis, or photosynthesis and cellular respiration.
- Compare and contrast two types of plant or animal cells: for example, cells from leaves and cells from roots, or epidermis cells and brain cells.
- Compare and contrast two breakfast cereals in order to decide which is a better buy and which is more nutritious.
- Use the compare and contrast strategy in a subject other than science to compare and contrast two ideas, stories, characters, historical figures, or countries that you have been studying in order to learn something important about them.

Reinforcement Later

- Compare and contrast two different pieces of music.
- Compare and contrast two animals or two plants that you are studying in science.
- Use the compare and contrast strategy to help you decide how you will spend some block of free time that you have on the next weekend.

WRITING EXTENSION

Write a compare and contrast essay about plant and animal cells, using your conclusion as the topic sentence or main idea. Use the first paragraph to explain your conclusion, the second to state important similarities between plant and animal cells that support your conclusion, and the third paragraph to indicate which differences also support your conclusion. End the essay with a concluding paragraph restating your topic sentence and adding closing comments about your main idea.

HIGH SCHOOL VERSION

This lesson can also be taught in high-school biology courses. Material from a high-school textbook or other source material used in high school can be used instead of the passages on plant cells and animal cells included in this lesson. A compare-and-contrast graphic organizer filled in by high school students is included at the end of this lesson as an example of what high-school students can do in comparing and contrasting these two types of cells.

**ASSESSING STUDENTS' THINKING
WHEN THEY COMPARE AND CONTRAST**

To assess this skill, ask students to write an essay to answer any of the application questions or others you select. Ask students to describe how they compared and contrasted the two subjects. Determine whether they are attending to each of the steps of comparing and contrasting, and whether they have determined significant similarities and differences between the two figures.

ANIMAL CELLS AND PLANT CELLS

MIDDLE SCHOOL SOURCE MATERIAL ON ANIMAL AND PLANT CELLS

ANIMAL CELLS

Cells are the basic units of life. Each cell can carry on the basic activities of living tissues. Animal cells are the building blocks of animal tissue. They are usually very small and require a microscope to be seen. They appear colorless and nearly transparent. Animal cells do many different jobs. For example, they can work as blood cells carrying oxygen or nerve cells conducting electric signals.

Animal cells are made up of many parts. They are surrounded by a cell membrane, which allows only needed substances like water and nutrients to pass through while it keeps important substances like genetic material inside. The cell membrane is flexible; therefore, animal cells can change shape.

Animal cells also have a nucleus, which controls the activities that take place in the cell. Inside the nucleus are chromosomes. These are rope-like structures made of DNA, a chemical that acts like a blueprint and carries instructions for making more cells.

The inside of the cell is filled with a jellylike fluid called cytoplasm. The cytoplasm is like a thick soup filled with small structures that have specific jobs to do in the cell. These structures are called organelles, and they work together to keep alive molecules used by the cell. Animal cells also have centrioles, a structure needed for cell reproduction.

Animal cells come from other animal cells by the process of cell division. During cell division, one cell makes a second copy of its genetic material, its nucleus and its organelles. The original cell divides in half, makes more cell membranes and becomes two smaller cells. Each cell grows until it reaches its original size.

Animal cells need energy to do all this work. They get the energy from food molecules. After food molecules are digested, they enter the cell and are used as fuel to produce chemical energy in a special organelle called a mitochondria. The process of converting food into chemi-

cal energy is called cellular respiration. This process requires oxygen and food and produces heat, carbon dioxide and water. The energy is then used to carry on activities like reproduction, growth, and movement.

PLANT CELLS

Plant cells are the building blocks of plant tissue. They are usually very small and require a microscope to be seen. They often appear green because many plant cells contain the green pigment chlorophyll. Plant cells can do many different jobs, including working as root cells absorbing water or as leaf cells collecting sunlight.

Plant cells are made up of many parts. They are enclosed in a two-layer covering made up of a cell membrane and a cell wall. The cell membrane allows only needed substances like water and nutrients to pass through and serves the dual purpose of keeping important substances inside. The cell wall is a rigid shell that surrounds the cell membrane. It is not very flexible. Therefore, most plant cells do not change shape. The cell wall gives plant cells a solid structure so that they can be built into structures like tree trunks.

Plant cells also have a nucleus, which controls cellular activities. Inside the nucleus are chromosomes. These are rope-like structures made of DNA, a chemical that acts like a blueprint carrying instructions for making more cells.

Cells are filled with a jellylike fluid called cytoplasm. The cytoplasm is like a thick soup filled with small structures that have specific jobs to do in the cell. These structures are called organelles, and they work together to keep alive molecules used by the cell. Plant cells also have a large central vacuole, which stores water.

Plant cells come from other plant cells by the process of cell division. During cell division, one cell makes a second copy of its genetic material, its nucleus and of its organelles. The original cell divides in half, makes more cell membranes, and becomes two smaller cells. Each cell then grows until it reaches its original size.

Plant cells need chemical energy to do all this. They get the energy in a process called photosynthesis. During photosynthesis the energy of sunlight is used to assemble food molecules in chloroplasts. The process requires carbon dioxide and water and produces oxygen and food

molecules. Then the food molecules are used as fuel to produce chemical energy in mitochondria. The chemical energy is then used to carry on activities like reproduction, growth, and movement.

Sample Student Responses • Plant and Animal Cells • Middle School

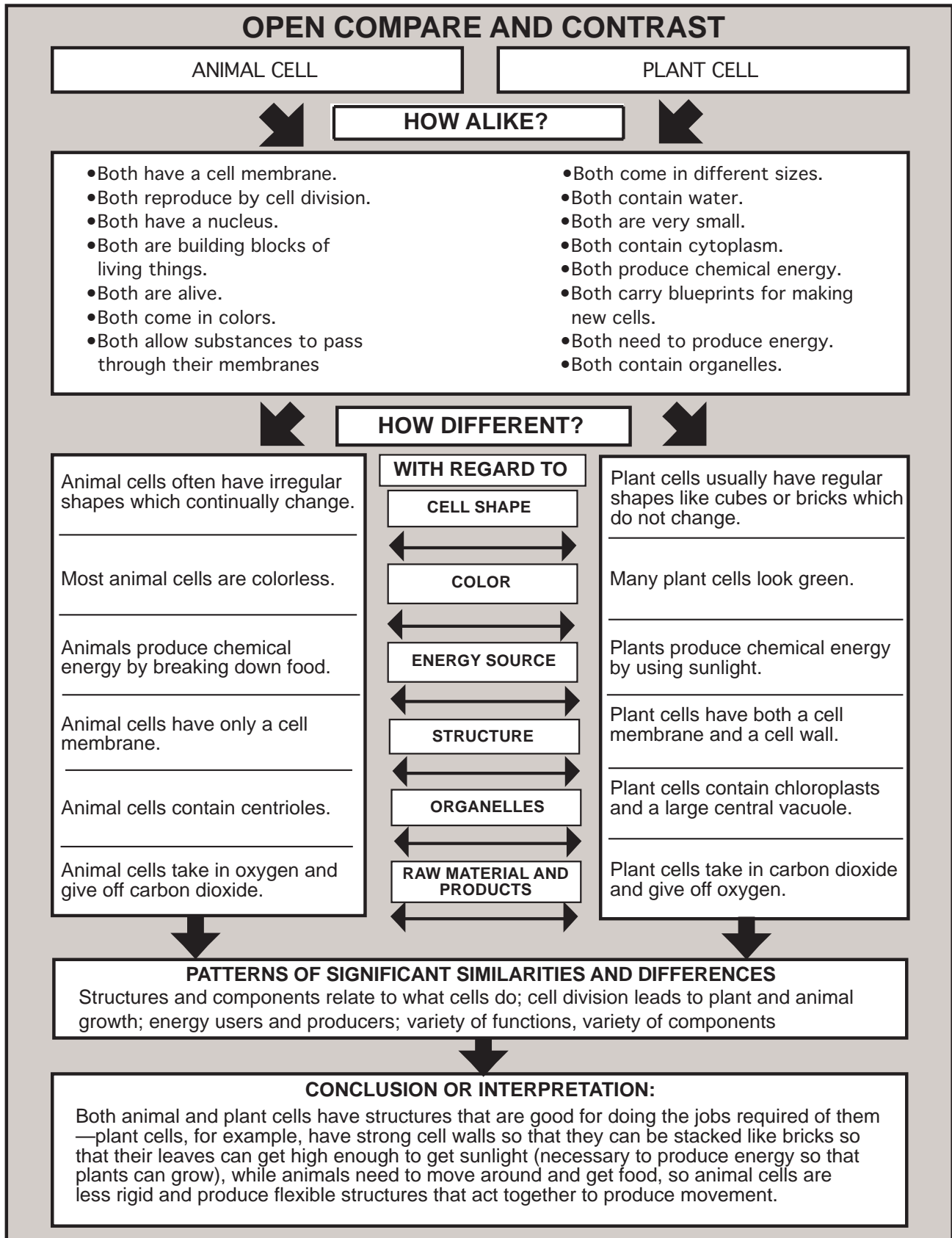

ANIMAL CELLS AND PLANT CELLS

HIGH SCHOOL SOURCE MATERIAL ON THE STRUCTURE OF ANIMAL AND PLANT CELLS

ANIMAL CELLS

The animal cell is the basic building block of animal tissue. It is usually microscopic. Animal cells have many specialized functions including those that provide structure, shape, nervous pathways, immunity, secretions, and reproductive machinery for the organism. Animal cells come in a variety of shapes and sizes ranging from the extremely small and round human egg to the extremely long motor neurons that connect our brains to our muscles. Animal cells can grow, respond to their environment, reproduce, and repair themselves.

A typical animal cell is made up of four major components. It has a cell membrane, a nucleus, a jellylike material called cytoplasm, and a set of structures suspended in the cytoplasm known as organelles. It also has an internal skeleton made up of tubes and fibers.

Many animal cell organelles are contained in their own cell membranes and include mitochondria, lysosomes, Golgi bodies, smooth and rough endoplasmic reticulum, and microbodies. Other cell structures, such as ribosomes and centrioles, do not have a cell membrane. Some animal cells, like the single cell of the protist *paramecium*, also contain small compartments called vacuoles, which collect excess water.

The animal cell nucleus is surrounded by a double cell membrane called a nuclear envelope, which is perforated by small passageways known as nuclear pores. The nucleus contains DNA, the cell's genetic material; DNA is found in long strands called chromatin that, during cell division, condenses into thicker coiled structures called chromosomes, which can be seen with the light microscope. The nucleus also contains a nucleolus, the site where ribosomes are manufactured, and a jellylike granular fluid called nucleoplasm.

The internal skeleton of the animal cell is a protein scaffold made up of three types of fibers: microfilaments, which can contract and cause

cells to move or change shape; intermediate filaments, which are very strong and anchor organelles within the cytoplasm; and microtubules, which are hollow tubes used to maintain cellular shape. Animal cells have a pair of microtubular structures called centrioles, which are used during cell division.

Animal cells can also have several long, whip-like projections called flagella, which are used for locomotion by sperm and other kinds of cells. Cilia also extend from the surface of many kinds of animal cells. Single-celled organisms use these cilia for movement, and complex animals use them to move material over the surface of cells. For example, cilia move mucus out of lungs.

The cytoplasm of the animal cell is a soup of water, dissolved nutrients, minerals, electrolytes, small molecular building blocks like amino acids, macromolecules such as hormones and enzymes, and metabolic waste.

The animal cell membrane separates the cell from its environment. Like other cellular membranes, it is made up of a double layer of lipid molecules called a phospholipid bilayer. It functions to control the movement of substances into and out of the cell. It is considered a selectively permeable membrane because it allows only some substances to pass through.

Energy in the form of adenosine triphosphate (ATP) is produced in mitochondria by breaking down the food molecule glucose. This energy is used to power all the activities of the cell. The process is called cellular respiration. It requires oxygen and food, and it produces heat, carbon dioxide, and water.

Animal cells reproduce by cell division. The process by which one cell produces two identical offspring cells is called mitosis. When the organism reproduces, specialized cells called sex cells produce gametes (sperm, eggs). The process by which gametes are produced from sex cells is called meiosis.

Although animal cells are flexible and at times mobile, they maintain a very constant internal environment. Each of the many different kinds of animal cells contributes to the overall stable internal environment of the organism. Keeping the environment stable is a process called homeostasis.

PLANT CELLS

The plant cell is the basic building block of plant tissue. It is usually microscopic. Plant cells have many specialized functions including those that provide structure, shape, protection, secretions and reproductive machinery for the organism. Plant cells come in a variety of shapes and sizes. They can grow, respond to their environment, reproduce, and repair themselves.

A typical plant cell is made up of four major components. It has a cell covering made up of a cell wall and cell membrane, a nucleus, a jellylike material called cytoplasm and a set of structures suspended in the cytoplasm known as organelles. It also has an internal skeleton made up of tubes and fibers.

Many plant cell organelles are contained in their own cell membranes and include mitochondria, chloroplasts, a central vacuole, lysosomes, Golgi bodies, smooth and rough endoplasmic reticulum, and microbodies. Other cell structures do not have a cell membrane—for example, ribosomes. Nearly all plant cells contain one or several large membrane-enclosed compartments called central vacuoles that contain water and enzymes, can enlarge and shrink, and function in cellular digestion in changing the cell's shape.

The plant cell nucleus is surrounded by a double cell membrane called a nuclear envelope which is perforated by small passageways known as nuclear pores. The nucleus contains DNA, the cells' genetic material, and is found in long strands called chromatin. During cell division, the chromatin condense into thicker coiled structures called chromosomes which can be seen with the light microscope. The nucleus also

contains a nucleolus, the site where ribosomes are manufactured, and a jellylike granular fluid called nucleoplasm.

The internal skeleton of the plant cell is a protein scaffold made up of three types of fibers: microfilaments which can contract and cause cells to move or change shape; intermediate filaments which are very strong and anchor organelles within the cytoplasm; and microtubules, which are hollow tubes used to maintain cellular shape.

The cytoplasm of the plant cell is a soup of water, dissolved nutrients, minerals, electrolytes, small molecular building blocks like amino acids, macromolecules such as hormones and enzymes, and metabolic waste.

In plant cells a cell wall made of cellulose surrounds the cell membrane. The cell wall functions to give plant cells rigidity for support. Plant cells communicate through adjacent cell walls via small channels called plasmodesmata. The plant cell membrane, like other cellular membranes, is made up of a double layer of lipid molecules called a phospholipid bilayer. It functions to control the movement of substances into and out of the cell. It is considered a selectively permeable membrane because it allows only some substances to pass through.

Energy in the form of ATP is produced in chloroplasts by converting the energy of sunlight into chemical energy. This energy is then used to produce the food molecule glucose. The process is called photosynthesis, requires carbon dioxide, water, and light energy, and produces glucose and oxygen. Plant cells then undergo cellular respiration in mitochondria where chemical energy stored in glucose made during photosynthesis is converted into ATP which is used to power all plant cell activities.

Plant cells reproduce by cell division. The process by which one cell produces two identical offspring cells is called mitosis. When a plant reproduces, specialized cells called sex cells produce gametes (sperm, eggs). The process by which gametes are produced from sex cells is called meiosis.

CROSS-SECTION OF AN ANIMAL CELL

- | | | | |
|---|------------------|---|---------------|
| A | Cell Membrane | E | Chromatin |
| B | Nuclear Envelope | F | Nuclear Sap |
| C | Nuclear Pore | G | Mitochondrion |
| D | Nucleolus | H | Golgi Complex |

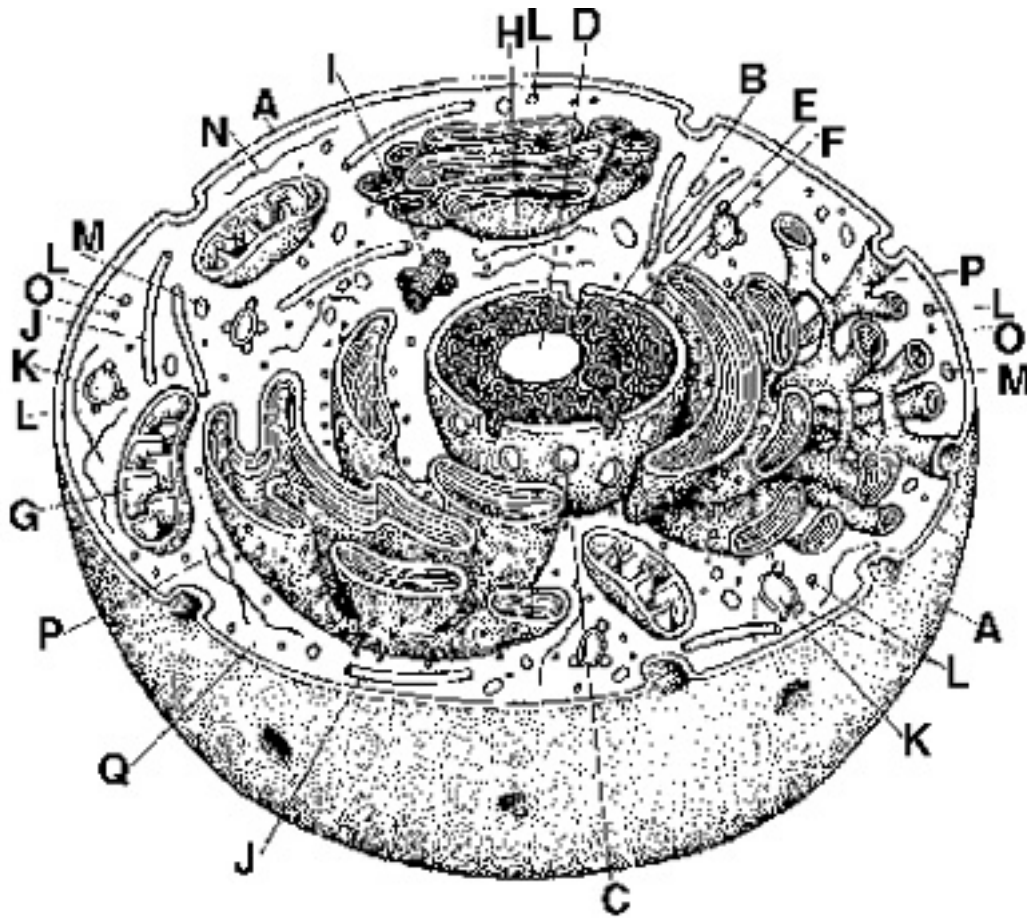

- | | | | |
|---|-------------|---|-----------------------|
| I | Centriole | N | Microfilament |
| J | Microtubule | O | Ribosome |
| K | Vacuole | P | Endoplasmic Reticulum |
| L | Lysosome | Q | Hyaloplasm |
| M | Microbody | | |

CROSS-SECTION OF A PLANT CELL

- | | |
|-----------------|---------------|
| A Cell Membrane | E Crystal |
| B Cell Wall | F Chloroplast |
| C Plasmodesma | G Leucoplast |
| D Vacuole | H Chromoplast |

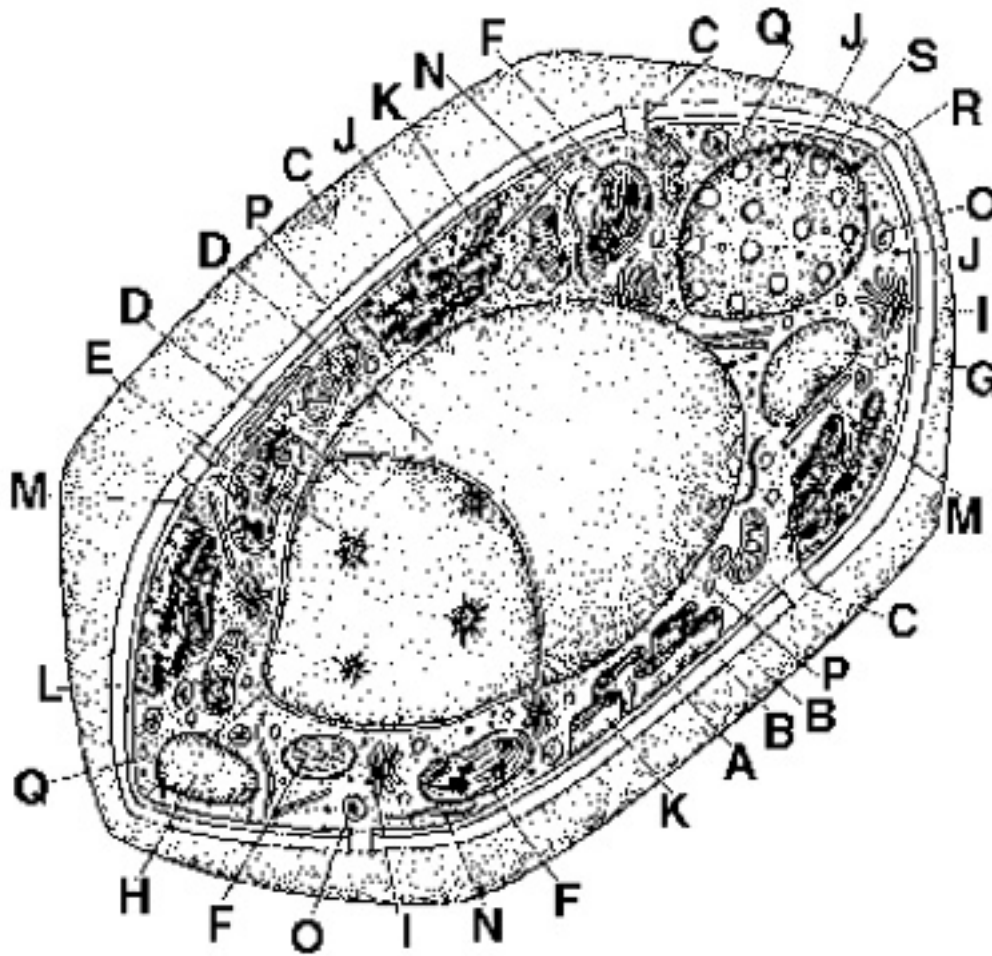

- | | |
|-------------------------|--------------------|
| I Golgi Complex | O Lysosome |
| J Ribosome | P Microbody |
| K Endoplasmic Reticulum | Q Hyaloplasm |
| L Mitochondrion | R Nuclear Envelope |
| M Microtubule | S Nuclear Pore |

Sample Student Responses • Plant and Animal Cells • High School

